

MADE IN ITALY



**POWER  
SYSTEM**  
AIR COMPRESSORS

Oil injected rotary  
screw compressors  
with gear drive transmission.

**NOBEL 75E**  
FIXED AND VARIABLE SPEED  
75 kW



# NOBEL 75E

Rotary screw compressors featuring direct drive.



## High efficiency with maximum energy savings

Power System engineered gear drive transmission. Optimised component technology. Utilisation of new generation high efficiency motors, drive and inverter technology.



## Silent

The very low operating speed along with the use of radial cooling fans allows NOBEL 75E series compressors to achieve the lowest noise levels in the sector.



## Simplified maintenance

All service access has been made simple and extremely convenient reducing down time and service costs.



## Controllo e regolazione ottimali

The innovative DNAir2 controller is specially designed for simple and flexible programming, it adjusts and controls the operation of the compressor, guaranteeing its efficiency and safety. The user-friendly interface consists of a large backlit LCD display, with simple and clearly understood icons. All commands and functions are accessed easily using multilingual drop-down menus.



## Robust construction

The gear drive transmission minimises maintenance and increases the reliability and longevity of the machine. The combination of proven technologies along with components designed and built by Power System, guarantees high efficiency and premium reliability.



## Remote monitoring and preventive maintenance

The optional "Service Management System" - SMS Device - ensures the remote control of the compressor and informs, via e-mail, the user or the service center about the status of the machine, signaling failures or the need to perform maintenance operations.

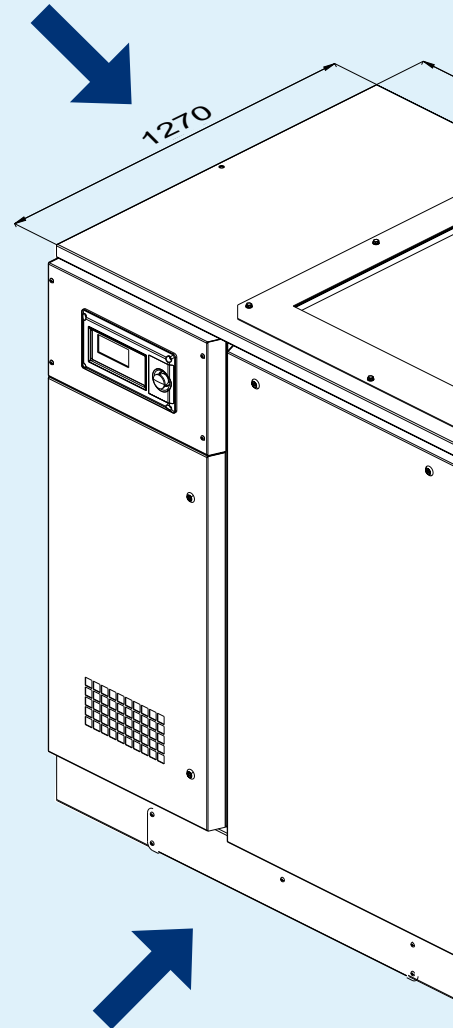

# Maximum compactness: all the efficiency and reliability of the Nobel in just 2 square meters of space!

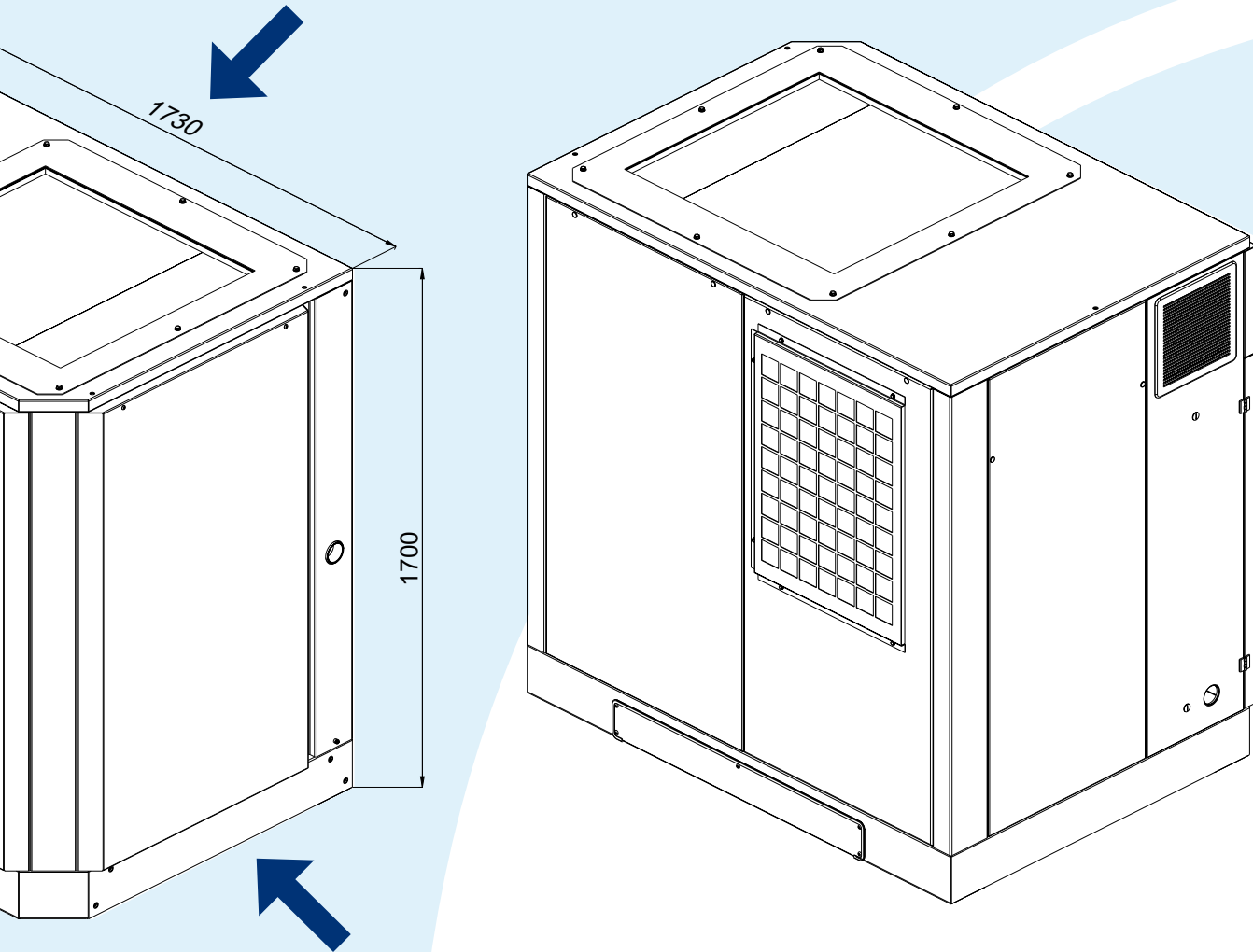

## NOBEL 75E

Code	Power		Air outflow rate (DV = max. / min.)		Max. pressure		Sound level dB(A)	Connec- tion Ø	Net weight		Net dimensions L x P x H (cm)	Gross weight		Gross dimensions L x P x H (cm)	
	kW	HP	m³/min.	c.f.m.	bar	p.s.i.			kg	Lbs		kg	Lbs		
<b>NOBEL 75E - Fixed speed</b>															
<b>NOBEL 75E-08</b>	<b>V60NC92PWS045</b>	75	100	12.6	445	7.5	109	72	2"	1440	3175	173x127x170	1560	3439	192x142x188
<b>NOBEL 75E-10</b>	<b>V60ND92PWS045</b>	75	100	10.5	371	10	145	72	2"	1440	3175	173x127x170	1560	3439	192x142x188
<b>NOBEL 75E-13</b>	<b>V60NE92PWS045</b>	75	100	8.7	307	13	189	72	2"	1440	3175	173x127x170	1560	3439	192x142x188
<b>NOBEL 75E - Variable speed</b>															
<b>NOBEL 75E-08 DV</b>	<b>V60NC97PWS045</b>	75	100	12.6 / 4.5	445 / 159	7.5	109	72	2"	1486	3276	173x127x170	1600	3527	192x142x188
<b>NOBEL 75E-10 DV</b>	<b>V60ND97PWS045</b>	75	100	10.5 / 3.8	371 / 134	10	145	72	2"	1486	3276	173x127x170	1600	3527	192x142x188
<b>NOBEL 75E-13 DV</b>	<b>V60NE97PWS045</b>	75	100	8.7 / 3.48	307 / 123	13	189	72	2"	1486	3276	173x127x170	1600	3527	192x142x188

Reference conditions: air intake temperature 20°C (68°F) – atmospheric pressure 1 bar (14.5 p.s.i.).

Air flow was measured in the following operative pressures: 7 bar for models at 7.5 bar - 9.5 bar for models at 10 bar - 12.5 bar for models at 13 bar.

The data and results were measured in accordance with standard ISO 1217.

The sound level was measured in accordance with standard ISO 3744.



### Thermostatic valve

Controls the coolant flow avoiding sudden temperature changes and reducing the risk of condensation being formed.

### DNAir2 controller

Simple and intuitive, sophisticated functionality and flexible programming.



### Inverter

The latest generation inverter drive, allowing a controlled use of energy minimising CO<sub>2</sub> output and lowering energy costs.



### Minimum pressure valve

Guarantee low pressure losses and reduced energy consumption.

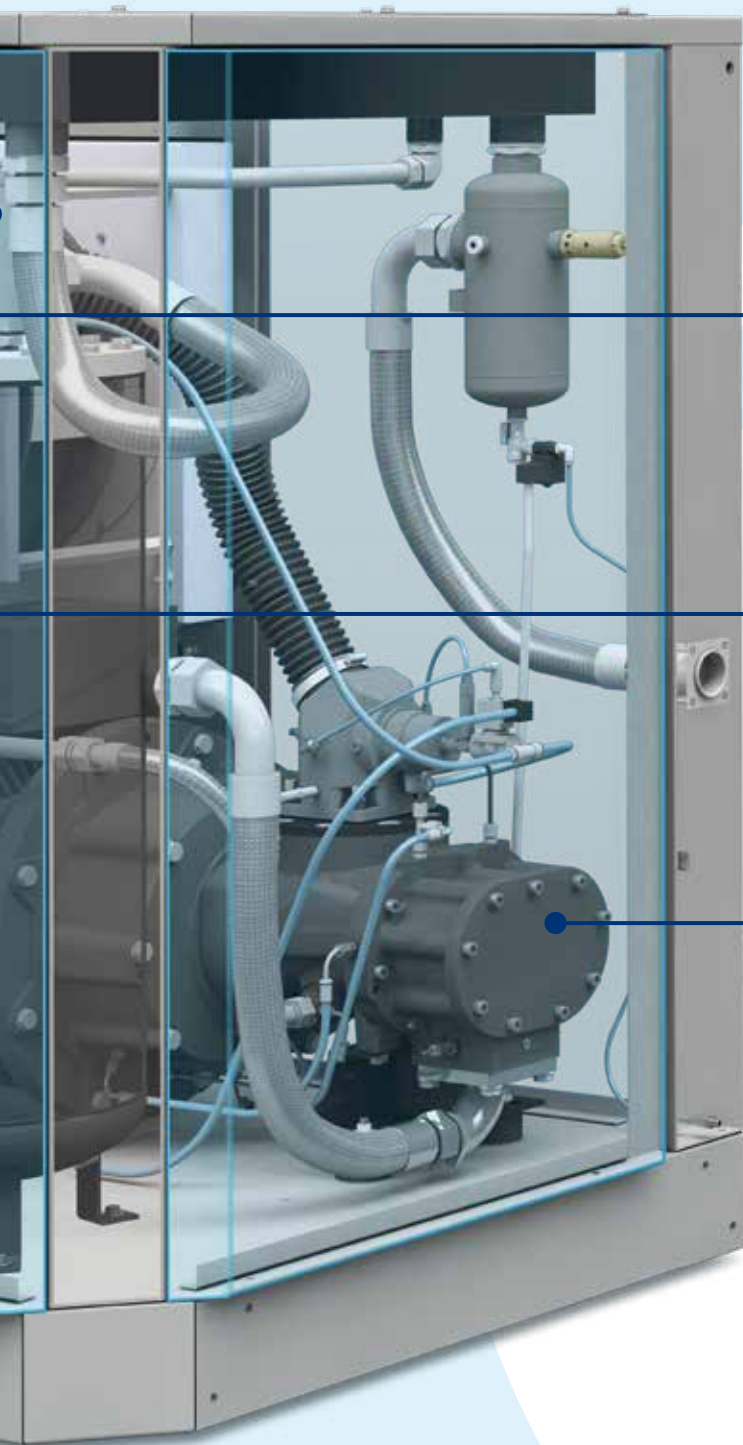

### Air filter and oil filter

Ideally positioned for easy access, simplifies maintenance.

Double stage air filter as standard on all models.



### Gear drive transmission system

Exclusive Power System design offering the highest efficiency with ultimate reliability.





### Heat exchangers

Generously dimensioned coolers combining high efficiency heat transfer and low pressure loss.



### Intake regulator

Guarantees high efficiency, reduced noise levels and high reliability.



### **Integrated condensate drain**

Available in standard configuration in all models and controlled by the DNAir2.



### **Radial ventilation**

Combines the highest cooling efficiency with reduced energy consumption and very low noise levels.

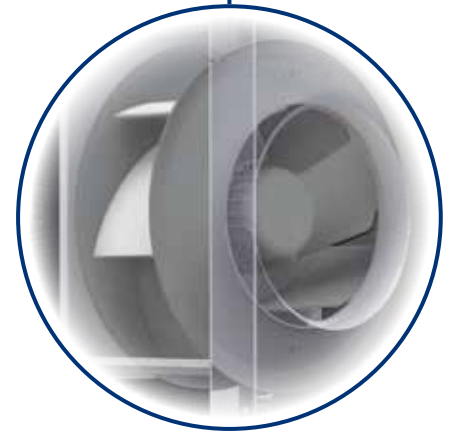

### **Easy maintenance**

The compressor can be fully opened on all 4 sides.

# NOBEL 75E DV

## Maximum energy efficiency

### Variable speed with inverter drive

The reduction of energy consumption and the protection of our precious environmental resources is one of the major global challenges in our times. Thanks to decades of experience in the industry, Power System is recognised as a technological leader in the field of variable speed compressors, capable of guaranteeing high performance levels and efficient energy solutions. The optimised frequency converter provides the capability to dynamically regulate the frequency, voltage and current values supplied to the main electric motor, constantly eliminating useless power drops, continuously adjusting the compressed air generation in line with the amount of compressed air that is required.

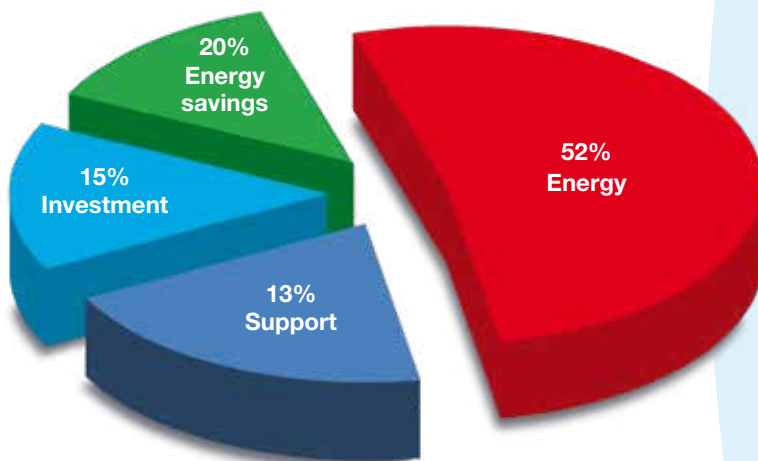

#### MANAGEMENT COSTS

*The graph shows the considerable energy savings achieved with a variable speed compressor in a typical installation.*

The benefits of using the NOBEL 75E DV with inverter are remarkable:

- continuous control and regulation of the volume of air generated by varying the speed of the electric motor from 30% up to 100% of the motors full speed;
- the compressed air generated is therefore constantly proportional to the requirements of the system;
- the pressure control inside the system is controlled accurately and precisely, in a range between 6 and 13 bar, depending on the chosen compressor model.



# Savings energy in your company? It is possible!

The energy efficiency of a production plant or any application using compressed air is most important as it may represent a very significant part of the whole energy consumption for the facility. The proper control of compressed air generation provides countless opportunities for the application to improve the whole production process, in terms of energy consumption, efficiency, costs and emissions.

Based upon decades of experience in the industrial sector, Power System provides a professional auditing service to our clients. Our skilled technicians, using advanced measurement and analysis equipment (EATool and EASoftware) can carry out a full audit of any system. This allows us to fully understand your system demands, existing energy consumption and wastage.

Our advanced simulation software then allows us to propose various technical options that are aimed at providing considerable economic and energy consumption based savings.

## EASoftware

- Using accurate data on the actual consumption or generation of compressed air in the system along with existing energy usage.
- Providing a complete and precise Energy Audit of the system (air generated, system load, pattern of use, pressure etc.).
- provides options for an alternative system that might include one or more compressors and controls as a possible alternative to the existing installation, to provide maximum energy savings and a reduction in wasted energy.



## EATool

- Designed to measure compressed air systems in which up to 4 compressors will operate.
- Measurements are downloaded to a USB drive or USB/PC.
- Supplied: up to 4 x 400 A ampere clamps (optional up to 1000A) and a pressure sensor.
- Capable of analysing over a long time period (usually eight days or more is ideal).

# Extend the life and efficiency of your compressor

In addition to offering the highest quality and technologically advanced products, Power System focuses its attention on customer care and full technical and product support, identifying our customer's needs and only then offering the most suitable solutions designed to work for our clients. Our professional technical support team provides on the phone assistance on all technical matters. We also provide on-site consultancy, maintenance plans, energy audits and training programmes etc.

## The importance of original spare parts ...

**FSN** is the brand of the original spare parts for all Power System compressors and identifies our after-sales services. FSN guarantees that all spare parts are original and that they have been carefully selected to satisfy our exacting standards and to meet critical performance and quality standards which are checked, tested and monitored by skilled technicians. Using FSN certified original spare parts reduces management costs and guarantees the efficiency, reliability and longevity of the compressor at the same time providing maximum operator safety and security. Our "Hot-Line" service, guarantees the delivery of urgent spare parts within 24 hours from the order.

## Long Life Kit for the scheduled maintenance of Power System screw compressors

To simplify the replacement of service items and to assist with efficient planning of routine maintenance, Power System has developed new spare parts packaging in the form of a "LONG-LIFE KIT", specially designed for each screw compressor model. By utilising our Long-Life Kit customers benefit from: increased maintenance intervals, improved energy efficiency, reduced costs and at the same time ensuring the product's continued performance and reliability and at the same time protecting your investment.

## RELY ON our TRUST

POWER SYSTEM's 30 years of premium quality Rotary Screw Compressors functioning all over the world is our undeniable proof of knowledge, experience, leadership in innovative and advanced solutions. This is where originates our total confidence and commitment in offering a range of extended warranty packages to our Clients allowing them to guarantee their investment to up to 5 years.

Preventive programmed maintenance routines carried out only by authorized skilled and experienced technical staff, genuine original spare parts, hundreds of different field applications experiences is what makes our products completely reliable over time.

Our TRUST Extended warranty packages are easily activated online through EasyConnect, the new portal of Power System services, specially created to allow our Clients a direct line with us, with fast and clear answers on product availability, orders management, technical literature database.



**We fear no comparisons. Choose TRUST, choose quality!**



## ... and specific lubricants

### Rotar ECOFLUID 46 cSt oil - Mineral base

#600000020	1 x 3.8 L (3.3 kg) tank
#600000021	1 x 20 L (17.36 kg) tank
#600000022	1 x 200 L (174 kg) drum

Formulated with high quality selected mineral base oils enhanced with advanced anti-oxidants, anti-wear (zinc free), rust preventers and antifoams, offers an optimal control of oxidation and residue deposits as well as an excellent level of thermal stability and oxidation to ensure the longevity of equipment and long life performances.

### RotEnergy Plus 46 cSt oil - Synthetic base

#600000018A	1 x 3.8 L (3.25 kg) tank
#600000009A	4 tanks x 3.8 L (3.25 kg) each
#600000007A	1 x 19 L (16 kg) tank
#600000012A	1 x 208 L (181 kg) drum

Ensures low operating temperatures, efficient water separation, reduces friction and energy consumption, extends maintenance intervals, ensures excellent lubrication of the bearings, guaranteeing maximum all round protection.

### RotEnergyFood 46 cSt oil - Synthetic base

#600000014A	4 tanks x 3.9 L (3.25 kg) each
#600000016A	1 x 19 L (18.5 kg) tank
#600000017A	1 x 208 L (175 kg) drum

High-quality lubricant for rotary screw compressors, suitable for use in the food industry, where specific quality standards are required.

Our FSN lubricants - whether synthetic or mineral - have been specially developed for our screw compressors top quality operativity in cooperation with a world leading manufacturer of Industrial lubricants. Available in various packaging formats and capacities and in multiple or 'bulk' packages.

*We recommend changing the oil according to the intervals reported in the use and maintenance manual of the compressor or once a year. We suggest using our RotarECOFLUID or RotEnergy oil (that are not included in the Long Life Kit).*



**FSN**  
ORIGINAL SPARE PARTS

You can download the Long-Life Kit catalogue from the website [www.powersystem.it](http://www.powersystem.it) where you will also find the compressors exploded views and spare parts list online, which are continuously updated for each compressor model.



**FNA S.p.A.**

*Registered office and sales department:*

Via Einaudi, 6 - 10070 Robassomero (TO) - Italy

Tel. +39 011 9233000 - Fax +39 011 9241138

*Production plant:*

Via Toscana, 21 - 40069 Zola Predosa (BO) - Italy

**info@fnacompressors.com**

**www.powersystem.it**



**The science of compressed air.**

